



P/N 01-9999-61

**BARRIER FREE SURFACE WALL MOUNT PULL DOWN EYEWASH  
WITH BACKING PLATE  
P/N 01040141**

**BARRIER FREE SURFACE WALL MOUNT PULL DOWN EYEWASH WITH  
BACKING PLATE  
INSTALLATION INSTRUCTIONS**

**PARTS LIST:**

- 1 – Backing Plate (Item #1)
- 1 – Pull Down Activation Eyewash (Item #2)
- 1 – Mounting Adapter (Item #3)
- 1 – Pipe Nut and Washer (Item #4)

1. Determine mounting location for Barrier Free Surface Wall Mount Pull Down Eyewash with Backing Plate.
2. The Americans with Disabilities Act (for drinking fountains) requires the eyewash heads, when in the activated position, to be 36" from the standing level. Measure 36" from the standing level and mark that position on the wall.
3. The B.F. Surface Wall Mount Pull Down Eyewash has a 1/2" MNPT threaded pipe nipple to attach to the supply line. Drill a 7/8" diameter hole in the wall to accept the 1/2" pipe nipple at the marked location. Also, at this time, drill a 1/8" diameter hole in the wall for the anti-vandal pin located on the eyewash valve. See mounting diagram on page 2 for hole locations.
4. Position the backing plate (item #1) on the wall so that the eyewash mounting holes on the backing plate and the wall are in line with each other. Attach the backing plate to the wall with the appropriate screws (supplied by customer).
5. Secure the eyewash unit to the wall by passing the pipe nipple and roll pin through the backing plate and wall and secure it to the wall with the pipe washer and nut. If necessary, use the mounting adapter to securely attach the unit to the wall. See diagram on page 2.
6. Support the supply line before attaching it to the eyewash unit.
7. Attach the supply line and test with normal testing procedures.

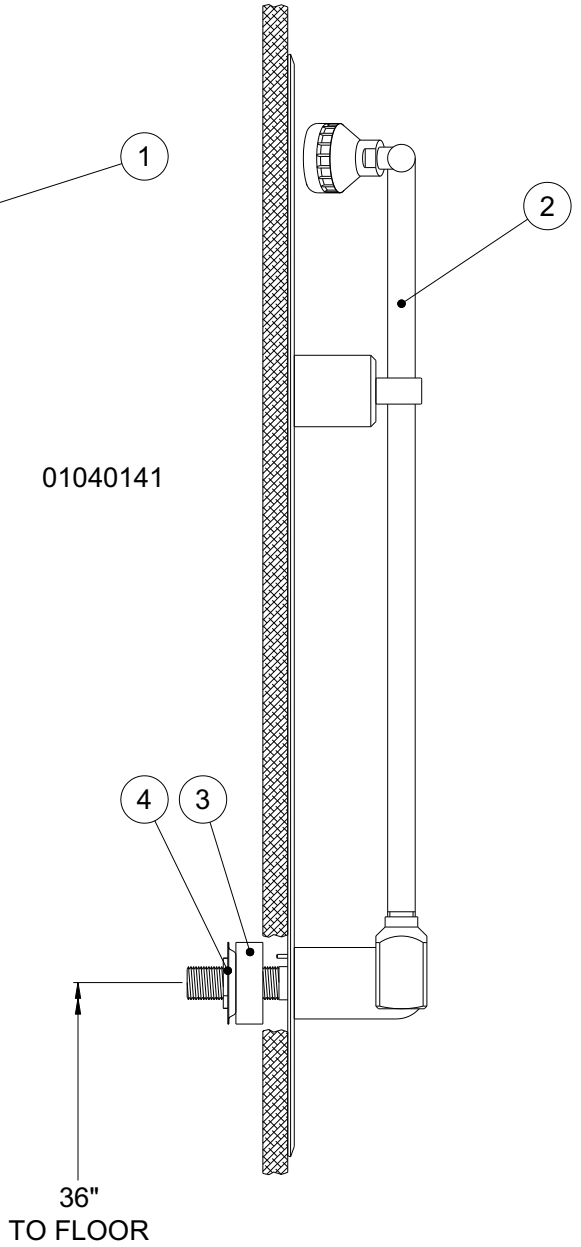
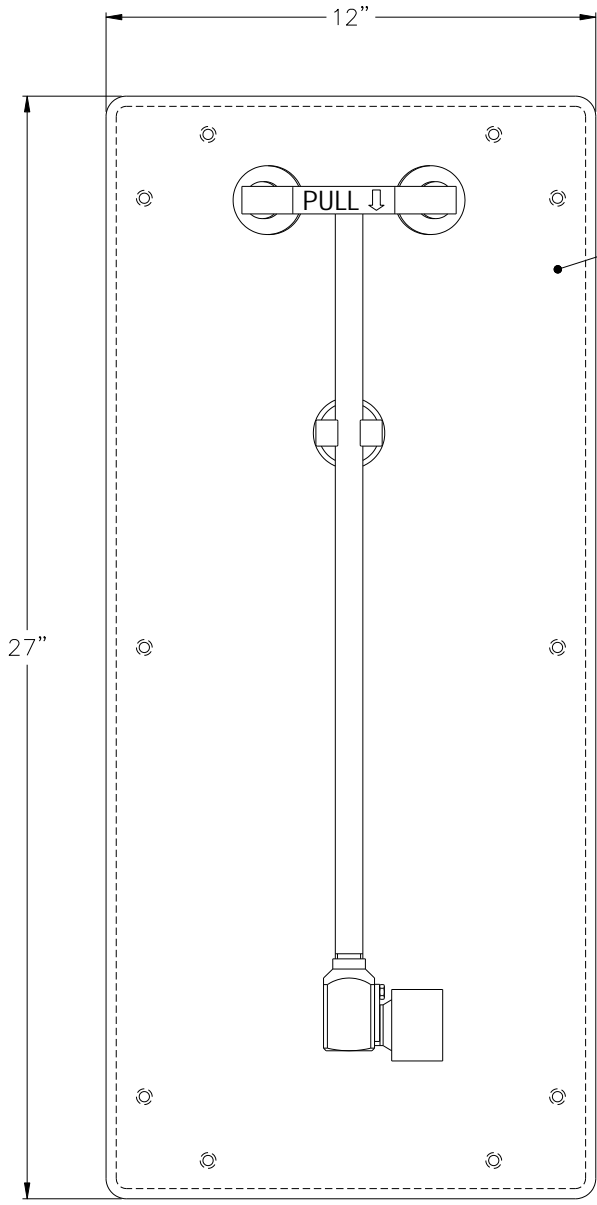

01040141

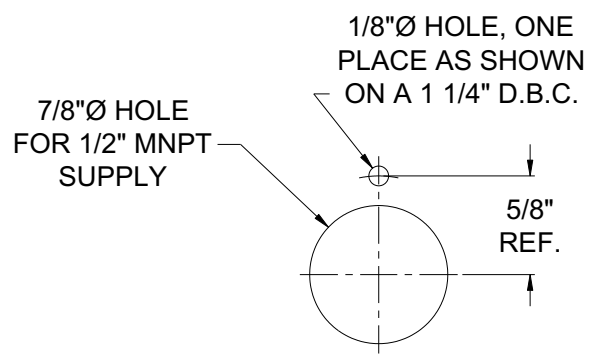

MOUNTING DIAGRAM

## **PROPOSITION 65**

WARNING: This product can expose you to BPA, which is known to the State of California to cause birth defects or other reproductive harm. For more information go to [www.P65Warnings.ca.gov](http://www.P65Warnings.ca.gov).

## **WARRANTY STATEMENT**

ENCON HEREBY DISCLAIMS ALL WARRANTIES EXPRESSED OR IMPLIED INCLUDING BUT NOT LIMITED TO WARRANTIES OF MERCHANTABILITY, FITNESS FOR A PARTICULAR PURPOSE, AND NON-INFRINGEMENT OF THIRD-PARTY RIGHTS, EXCEPT AS HEREINAFTER PROVIDED.

Encon Safety Products warrants that for one year from the date of purchase of any Encon products, the product will be free of defects in materials and workmanship if properly used and cared for or cleaned under normal conditions in accordance with Encon's use and care instructions and properly installed, if applicable, in accordance with Encon's installation instructions. With respect to the product, Encon's only obligation and purchaser's exclusive remedy under this warranty is to repair or replace such product; provided that:

1. Encon is notified of the defect within one year of shipment, and
2. the product is determined by Encon to be defective.

Encon requires proof of original ownership as proof of warranty coverage, and Encon must receive any claim under this Limited Warranty within one year of purchase of the product.

NOTWITHSTANDING ANYTHING TO THE CONTRARY CONTAINED HEREIN, ENCON SHALL NOT BE LIABLE FOR LOSS, DAMAGE, OR EXPENSE ARISING DIRECTLY OR INDIRECTLY AS A CONSEQUENCE OF USE OF THE EQUIPMENT WITH OTHER PRODUCTS OR FROM ANY OTHER CAUSE, INCLUDING ANY CONSEQUENTIAL, INCIDENTAL, SPECIAL OR EXEMPLARY DAMAGES, EXCEPT FOR ENCON'S OBLIGATION TO REPAIR OR REPLACE DEFECTIVE PRODUCTS AS EXPRESSLY PROVIDED IN THIS STATEMENT.

Replacement parts purchased from Encon are warranted for one year following the shipment of such replacement part, or until the expiration of the warranty period for the product, whichever is less. No warranty is given in connection with products that are altered without Encon's expressed written consent. The same warranty limitations and the obligations of Encon as set out herein above shall apply to replacement parts.

Encon's total liability arising out of this warranty (including, but not limited to, warranty claims) regardless of forum and regardless of whether such action or claim is based on tort, contract or otherwise will not exceed the total purchase price of the product.



6825 W. Sam Houston Pkwy. N  
Houston, TX 77041  
1-800-AT-ENCON / 1-800-283-6266  
[customerservice@enconsafety.com](mailto:customerservice@enconsafety.com)  
<http://www.enconsafety.com>